

Product Datasheet

description:	FUT 60L BLEU 2,05KG11843 EPDM/56x4 24x4 -36/PERDU	year:	2013
product group:	Small Tight Head	last revision:	2013-09-13
Mauser product no.:	FR060T2AB51538	print date:	2021-02-23
customer item no.:		page:	1/2

DIMENSIONS

A:	620.00 mm / +4
B:	./.
C:	400.00 mm
D:	./.
E:	420.00 mm

MATERIAL

plastic (body)a:	2.10 kg
plastic tolerance (+/-):	5 %
plastic total:	2.10 kg
steel:	0.00 kg

VOLUME

Volume:	60 L/15 GAL
brimful volume:	63 L / 17 GAL

DRAWING NUMBER

Mauser drawing no.:	./.
---------------------	-----

LABELING

Embossing/Label/Printing:	./.
label:	
customer spec no.:	

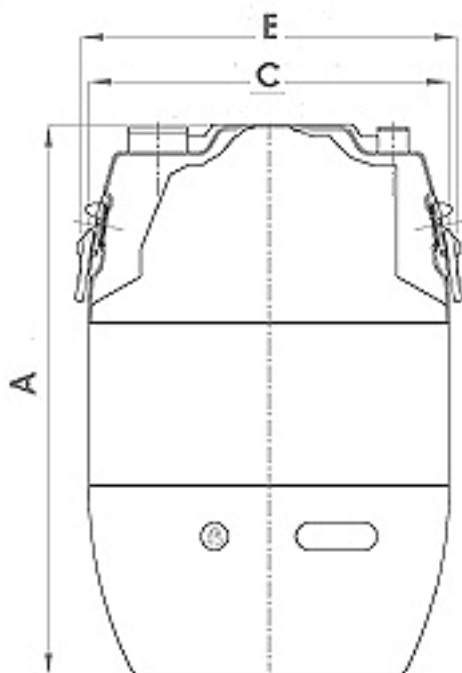

Drawing only exemplary

MAUSER France SAS

8 rue de la Gare F-60110 Esches France
 Phone: +33 (0) 344526350 Fax: +33 (0) 344526379
 info.fr@mauserpackaging.com
 http://www.mauserpackaging.com

Product Datasheet

description:	FUT 60L BLEU 2,05KG11843 EPDM/56x4 24x4 -36/PERDU		
product group:	Small Tight Head	year:	2013
Mauser product no.:	FR060T2AB51538	last revision:	2013-09-13
		print date:	2021-02-23
		page:	2/2

MODEL / COMPONENTS / ACCESSORIES

Design:	Bondel	Color:	blue
Accessories (Handle, RFID, tc.):	Handle, side	Layer:	1x
treatment/function:	./.	Gasket:	EPDM
Quality:	FoodProtect	Bung / Neck Geometry 2:	BCS 24x4
Bung / Neck Geometry 1:	BCS 56x4	Bung / Neck Closure 2a:	bung closure accord.to bung geometry
Bung / Neck Closure 1a:	bung closure accord.to bung geometry	Bung / Neck Closure 2b:	./.
Bung / Neck Closure 1b:	with 3/4" inside	Venting 2:	./.
Venting 1:	./.	Seal Cap 2:	./.
Seal Cap 1:	./.		

SHIPPING UNIT

Pallet Type:	loose	Pallet Material:	Wood, untreated
pieces per pallet:	36	Bung Orientation on Pallet:	./.
Load Secure:	Hood natural	Assembly Bung Closure 2:	To defined torque
Assembly Bung Closure 1:	loose screwed	Assembly Seal Cap 2:	./.
Assembly Seal Cap 1:	./.		

PACKAGING GROUP

Packaging Group:	Y	max. Density (Approval):	1,4 g/cm3
Hydraulic Pressure:	150 kPa		

STANDARD FILLING PRODUCTS

	max. vapour pressure at 50C	max. vapour pressure at 55C	density PG I	density PG II	density PG III
solid:	./.	./.	./.	./.	./.
water:	143.0	166.0	./.	1.4	1.4
acetic acid:	143.0	166.0	./.	1.2	1.2
wetting solution:	143.0	166.0	./.	1.2	1.2
white spirit:	143.0	166.0	./.	1.2	1.2
n-butyl acetate:	143.0	166.0	./.	1.2	1.2
nitric acid 55%:	143.0	166.0	./.	1.4	1.4

approval:	1H1/Y 1.4/150/--/D/BAM 11843-MESA-*
material type:	HDPE